



# BANDIT NEWS

Quarterly information sheet: **January 2005** ©

Publisher: Bandit nv / sa. Nijverheidslaan 1547, B-3660 Opglabbeek

Tel: +32 89 / 85 85 65 - Fax: +32 89 / 85 23 64 - Web: [www.bandit.be](http://www.bandit.be)

## **C**ontents:

Page 1:

- **Active security.**

Page 2:

- **HY-3 pack** - technical.

Page 3:

- **CNPP** approval in France.

Page 4:

- **BANDIT UK** established.

- **Active security** in the press.

## Active security

The preventive measures required when minimizing the damage caused by burglary and hold-up have been tightened up continuously, and have undergone accelerated development during recent years.

Primarily concerning aggressive hold-ups and fast burglary (ram raiding), which are at the top of the crime statistics.

The classic alarm installation suffices in cases of regular burglary and ram raid; the system of detection, processing and alarming works really well. Nevertheless it still appears that they are ineffective in preventing serious damage caused by burglary or ram raid.

One still has to wait for physical human intervention and criminals make good use of these first "dead" minutes. A suitable answer for this growing social and economic problem comes from a niche sector of the current security branch: **active security**.

The technologies employed to provide "active security" are systems that provide an immediate contribution to the security of the user and his possessions in a lawful manner.

In the world of professional security, fog generators are regarded as by far the best means to insure "loot" limitation. To offer the same level of protection in the form of a structurally secure compartment would require a property investment that is tens times more expensive.



*Even if you were Diogenes sat in his tub, someone would always find a way of stealing your candle.*

## HY-3 pack technical

Mechanically the interior section of the **BANDIT** comprises two main components:

- The heat exchanger: this chrome-steel cylinder is full of hot gassing channels that facilitates the rapid change of the injected *HY-3* liquid into a dry fog.
- The *HY-3* pack: is a cassette system containing the fog liquid and is comprised of the following integrated components: double *HY-3* liquid reservoirs, NC-valve, liquid filter, over-pressure disk and electronics for level- and data- status memory, temperature measurement, fog ejection registration and communication with the device.

The *HY-3* pack containers remain under constant vapour pressure due to a special HFC-propellant gas (one of the modern refrigeration gasses currently used for the so-called "green" fridges).

As soon the integrated valve is activated by the controlling **BANDIT** electronics, the vapour pressure of ~15 BAR (1.500 kPa or 220 PSI) provides a powerful and constant injection of *HY-3* liquid into the heat exchanger.



*HY-3* pack with neutral fog intended for and accepted by the 240 devices. Indicated by black canisters and the label mark RF (Regular Fog).



*HY-3* pack with neutral fog intended for and accepted by the 240 demonstration devices. Indicated by blue canisters and the label mark DF (Demo Fog). The purchase price for these is the same as for the regular (RF) cassette, but the refill price is 50% lower.

*HY-3 grip tool, supplied with each device.*

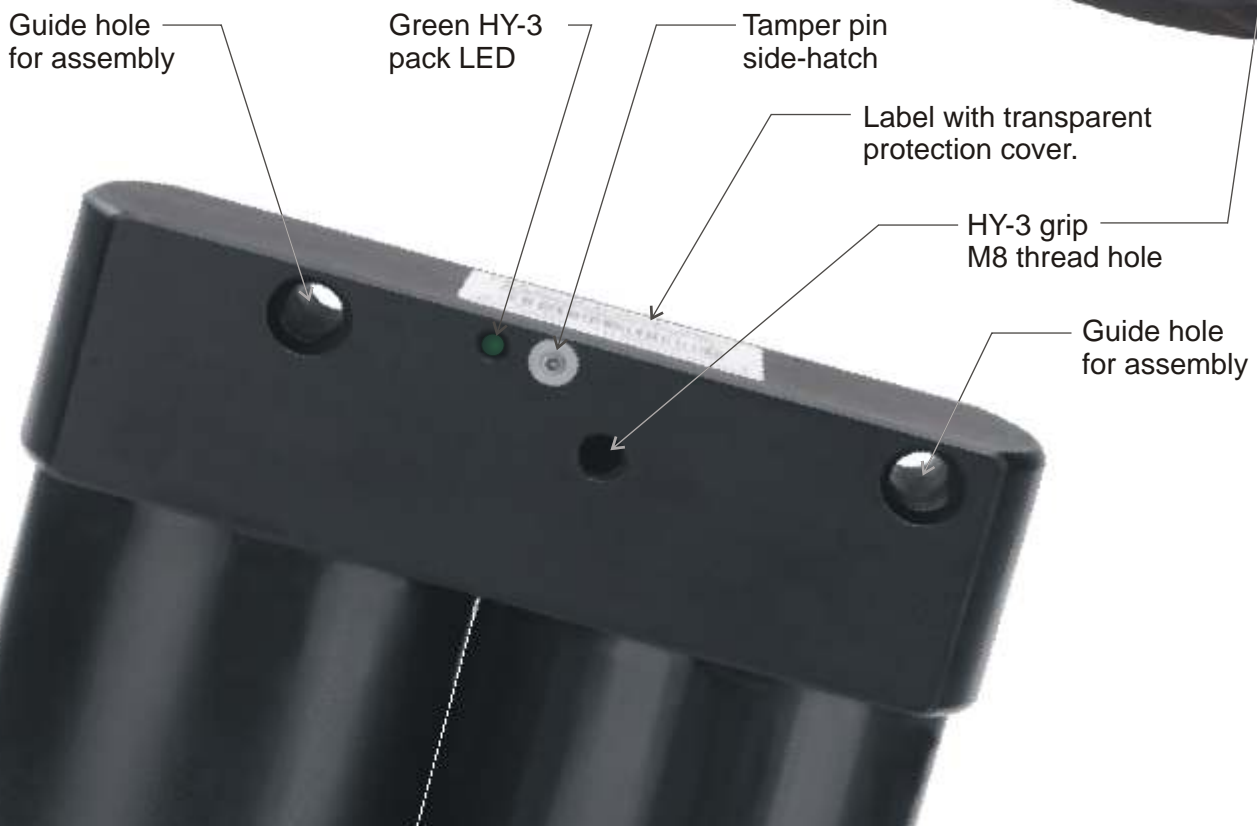



**BANDIT 240** side view with installed HY-3 pack and side hatch open.

A fully filled HY-3 pack contains 1.4 liter (1400 ml) of HY-3 liquid. Ejecting fog consumes approximately 28 ml of liquid per second. So in total approx. 50 seconds of fog ejection is available in a single HY-3 pack. The device electronics communicate continuously with the HY-3 pack electronics and based on given parameters it permanently calculates how much liquid remains in the HY-3 pack. When the supply of HY-3 liquid depletes to 30% the device will "ask" for a refilled HY-3 pack.

The major advantage of this technology over the traditional pump system (such as fog generators used in the entertainment industry) is the high reliability and unequaled fog ejection power plus the superb fog quality (completely aerosol).

Thanks to the cassette principle the replacement of an HY-3 pack at the service location takes only five minutes.

The empty cassette is refilled in the factory, technically examined and redelivered as a new



### CNPP approval in France

CNPP-approval is required for security materials by virtually all French insurance companies and government bodies. This approval is comparable with our Belgian BVVO-approval.

The major problem posed in acquiring the attestation of approval was due to the fact the CNPP had never previously handled an approval request for a fog generator.

It's taken two years for **BANDIT** France (Bandit-distribution in France) to achieve the CNPP approval for the 240DB model. There is currently an additional request for approval in the pipeline for the 240PB model (PC / laptop version).

This certification opens new commercial possibilities in the French market and underlines once again the capabilities of our **BANDIT**-France colleagues. Thanks to its quality and performance **BANDIT** is the only CNPP approved fog generator in the French market.



## **BANDIT UK Ltd. established.**

Although we received nice orders from reference customers such as “Tesco” (largest supermarket chain in the UK), the English market is a lot bigger than the access that we've had until now. Because of the establishment of **BANDIT UK Ltd.** we think that the efforts of people working full-time from the 1<sup>st</sup> of November onwards on domestic **BANDIT**-promotion, distribution and support will help to sell an extra 1,200 devices in the British market.



Enzo Koflach  
Managing Director



Richard Lewis  
Technical Director



Keith Holland  
Commercial Director

The three directors of **BANDIT UK Ltd.** have accumulated more than 40 years experience in the security industry.

## **Press announcements**

Being the inspiration behind and manufacturer of our **BANDIT** fog generators naturally we're interested in whatever the press has to report about active security and our product.

Articles pop up almost every week indicating the important role that active security plays within the total concept of security.

According to the remarkable results of active security, it's become an unstoppable trend.



Article published with the permission of Service station manager: Kris Aerts

## **REGIONAL NEWS**

### **HAM**

### **Fog generator chases thieves out of service station shop**

Around 3.30 h. on Thursday morning a burglary occurred at a service shop in the Heidestraat at Kwaadmechelen (Belgium). The perpetrators fled empty handed, the fog generator in the shop scared them off. Service station manager Kris Aerts had installed a fog generator into his premises. "After a big cigarette burglary 5 years ago I had a fog generator installed on our alarm system", said Kris. When there's a burglary the fog generator fills the whole shop with fog. You can't see your hand in front of your face. This is the way we can hinder attempts at theft. The thieves had been behind the counter; we could see that from the blood stains. "They'd smashed the glass panel in the door to get in. That's what set off the alarm and filled the shop with fog. It's an efficient protection", said the service station manager. Witnesses saw two or three thieves leaving the scene in a dark coloured car.

MaW

Article from the newspaper "Het belang van Limburg" from: 01 oktober 2004, page 15

The device that chased off the villains was an "old" 220-model, installed by the alarm-installer back in 1999. Back then the **BANDIT** installation cost 1,090 Euro. According to the owners estimation the installation has prevented 10,000 Euro (7,050 GBP) worth in certain theft damage.